

**INSTALLATION NOTES:**

- ONE (1) INSTALLATION ANCHOR IS REQUIRED AT EACH ANCHOR LOCATION SHOWN.
- THE NUMBER OF INSTALLATION ANCHORS DEPICTED IS THE MINIMUM NUMBER OF ANCHORS TO BE USED FOR PRODUCT INSTALLATION.
- INSTALL INDIVIDUAL INSTALLATION ANCHORS WITHIN A TOLERANCE OF ±1/4 INCH OF THE DEPICTED LOCATION IN THE ANCHOR LAYOUT DETAIL (I.E., WITHOUT CONSIDERATION OF TOLERANCES). TOLERANCES ARE NOT CUMULATIVE FROM ONE INSTALLATION ANCHOR TO THE NEXT.
- SHIM AS REQUIRED AT EACH INSTALLATION ANCHOR WITH LOAD BEARING SHIM(S). MAXIMUM ALLOWABLE SHIM STACK TO BE 1/4 INCH. SHIM WHERE SPACE OF 1/16 INCH OR GREATER OCCURS. SHIM(S) SHALL BE CONSTRUCTED OF HIGH DENSITY PLASTIC OR BETTER.
- FOR INSTALLATION INTO WOOD FRAMING USE #10 WOOD SCREWS OF SUFFICIENT LENGTH TO ACHIEVE 1 1/4 INCH MINIMUM EMBEDMENT INTO WOOD SUBSTRATE.
- FOR INSTALLATION THROUGH 1X BUCK TO CONCRETE/MASONRY, OR DIRECTLY INTO CONCRETE/MASONRY, USE ) 3/16 INCH DIAMETER ITW TAPCONS OF SUFFICIENT LENGTH TO ACHIEVE 1 1/4 INCH MINIMUM EMBEDMENT WITH 2 1/2" MIN. EDGE DISTANCE.
- FOR INSTALLATION INTO STEEL STUD FRAME USE #10-16 TEK SCREWS OF SUFFICIENT LENGTH TO ACHIEVE A MINIMUM 3 THREADS PENETRATION BEYOND STEEL STRUCTURE.
- MINIMUM EMBEDMENT AND EDGE DISTANCE EXCLUDE WALL FINISHES, INCLUDING BUT NOT LIMITED TO STUCCO, FOAM, BRICK VENEER, AND SIDING.
- INSTALLATION ANCHORS AND ASSOCIATED HARDWARE MUST BE MADE OF CORROSION RESISTANT MATERIAL OR HAVE A CORROSION RESISTANT COATING.
- FOR HOLLOW BLOCK AND GROUT FILLED BLOCK, DO NOT INSTALL INSTALLATION ANCHORS INTO MORTAR JOINTS. EDGE DISTANCE IS MEASURED FROM FREE EDGE OF BLOCK OR EDGE OF MORTAR JOINT INTO FACE SHELL OF BLOCK.
- INSTALLATION ANCHORS SHALL BE INSTALLED IN ACCORDANCE WITH ANCHOR MANUFACTURER'S INSTALLATION INSTRUCTIONS, AND ANCHORS SHALL NOT BE USED IN SUBSTRATES WITH STRENGTHS LESS THAN THE MINIMUM STRENGTH SPECIFIED BY THE ANCHOR MANUFACTURER.
- INSTALLATION ANCHOR CAPACITIES FOR PRODUCTS HEREIN ARE BASED ON SUBSTRATE MATERIALS WITH THE FOLLOWING PROPERTIES:
  - WOOD - MINIMUM SPECIFIC GRAVITY OF 0.55.
  - CONCRETE -MINIMUM COMPRESSIVE STRENGTH OF 2730 PSI.
  - GROUT-FILLED CMU- UNIT STRENGTH CONFORMS TO ASTM C-90 WITH MINIMUM COMPRESSIVE STRENGTH OF 1924 PSI AND GROUT CONFORMS TO ASTM C 476, MINIMUM GROUT COMPRESSIVE STRENGTH OF 2000 PSI.
  - HOLLOW BLOCK CMU - UNIT STRENGTH CONFORMS TO ASTM C-90 WITH MINIMUM COMPRESSIVE STRENGTH OF 1924 PSI.
  - STEEL - MINIMUM YIELD STRENGTH OF 36 KSI. MINIMUM WALL THICKNESS OF 48 MIL (0.048" or 18 GAUGE). MIN. 1/2" EDGE DISTANCE.

**GENERAL NOTES:**

- THE PRODUCT SHOWN HEREIN IS DESIGNED AND MANUFACTURED TO COMPLY WITH THE 2007 & 2010 FLORIDA BUILDING CODE (FBC), INCLUDING HVHZ AND HAS BEEN EVALUATED ACCORDING TO THE FOLLOWING:
  - TAS 201-94
  - TAS 202-94
  - TAS 203-94
- ADEQUACY OF THE EXISTING STRUCTURAL CONCRETE/MASONRY AND 2X FRAMING AS A MAIN WIND FORCE RESISTING SYSTEM CAPABLE OF WITHSTANDING AND TRANSFERRING APPLIED PRODUCT LOADS TO THE FOUNDATION IS THE RESPONSIBILITY OF THE ENGINEER OR ARCHITECT OF RECORD FOR THE PROJECT OF INSTALLATION.
- 1X AND 2X BUCKS (WHEN USED) SHALL BE DESIGNED AND ANCHORED TO PROPERLY TRANSFER ALL LOADS TO THE STRUCTURE. BUCK DESIGN AND INSTALLATION IS THE RESPONSIBILITY OF THE ENGINEER OR ARCHITECT OF RECORD FOR THE PROJECT OF INSTALLATION.
- THE INSTALLATION DETAILS DESCRIBED HEREIN ARE GENERIC AND MAY NOT REFLECT ACTUAL CONDITIONS FOR A SPECIFIC SITE. IF SITE CONDITIONS CAUSE INSTALLATION TO DEVIATE FROM THE REQUIREMENTS DETAILED HEREIN, A LICENSED ENGINEER OR ARCHITECT SHALL PREPARE SITE SPECIFIC DOCUMENTS FOR USE WITH THIS DOCUMENT IN NON-HVHZ AND TO BE REVIEWED BY BUILDING OFFICIAL FOR HVHZ. DEVIATION FROM NOA REQUIRES ONE TIME APPROVAL BY MIAMI-DADE COUNTY (BCCO).
- APPROVED IMPACT PROTECTIVE SYSTEM **IS NOT REQUIRED** ON THIS PRODUCT IN AREAS REQUIRING IMPACT RESISTANCE.
- DOOR FRAME MATERIAL: SOLID MAHOGANY
- DOOR FRAME MATERIAL: MAHOGANY (MIN. S.G.=0.44). ALL WOOD COMPONENTS TO BE EQUAL OR STRONGER.
- IN ACCORDANCE WITH THE 2007 & 2010 FBC, SECTION 2411.3.3.3 WOOD COMPONENTS SHALL HAVE BEEN PRESERVATIVE TREATED OR SHALL BE OF A DURABLE SPECIES AS DEFINED IN SECTION 2326.2.
- IN ACCORDANCE WITH THE 2007 & 2010 FBC SEC. 2003.8.4 DISSIMILAR METALS INCLUDING FASTENERS THAT MAY COME INTO CONTACT WITH ALUMINUM UNIT FRAMING SHALL BE PROTECTED AS DEFINED IN SEC 2003.8.4.2.

# ETO DOORS

## WOOD OPAQUE INSWING IMPACT RATED DOORS

TABLE OF CONTENTS		
SHEET	REVISION	SHEET DESCRIPTION
1	-	INSTALLATION & GENERAL NOTES
2	-	ELEVATIONS & ANCHOR LAYOUTS
3	-	ELEVATION, ANCHOR LAYOUT, & PANEL DETAIL
4	-	VERTICAL & HORIZONTAL SECTIONS
5	-	HORIZONTAL SECTIONS
6	-	COMPONENTS & BILL OF MATERIALS
7	-	QUALIFIED CONFIGURATIONS

DESIGN PRESSURE RATING		
DESIGN PRESSURE - ALL SIZES	MISSILE IMPACT RATING	
<b>+70*/- 70 PSF</b>	NOT RATED FOR WATER INFILTRATION	LARGE AND SMALL MISSILE IMPACT RATED

\*UNIT SHALL BE INSTALLED AT LOCATION PROTECTED BY OVERHANG SUCH THE OVERHANG RATIO (OH) = OH LENGTH/OH HEIGHT GREATER THAN 1.0 WHERE WATER INFILTRATION IS REQUIRED.



ETO DOORS  
1340 E. 6TH STREET  
LOS ANGELES, CA 90021  
PH: (213) 622-2003  
WWW.ETODOORS.COM

TITLE: WOOD OPAQUE I/S  
IMPACT RATED DOORS  
INSTALLATION  
& GENERAL NOTES

PREPARED BY:  
BUILDING DROPS  
127 W. FAIRBANKS AVE., STE. 438  
WINTER PARK, FL 32789  
PH: (407) 644-6987 FX: (407) 644-2366

REVISIONS	NO.	DESCRIPTION	BY	DATE



DATE: 12.08.11	DWN BY: JLA	CHK BY: HFN	SCALE: NTS
-------------------	----------------	----------------	---------------

DWG #:  
**ETO005**  
SHEET: **1 OF 7**

TITLE: WOOD OPAQUE I/S  
IMPACT RATED DOORS  
ELEVATIONS  
& ANCHOR LAYOUTS

PREPARED BY:  
BUILDING DROPS  
127 W. FAIRBANKS AVE., STE. 438  
WINTER PARK, FL 32789  
PH: (407) 644-6957 FX: (407) 644-2366

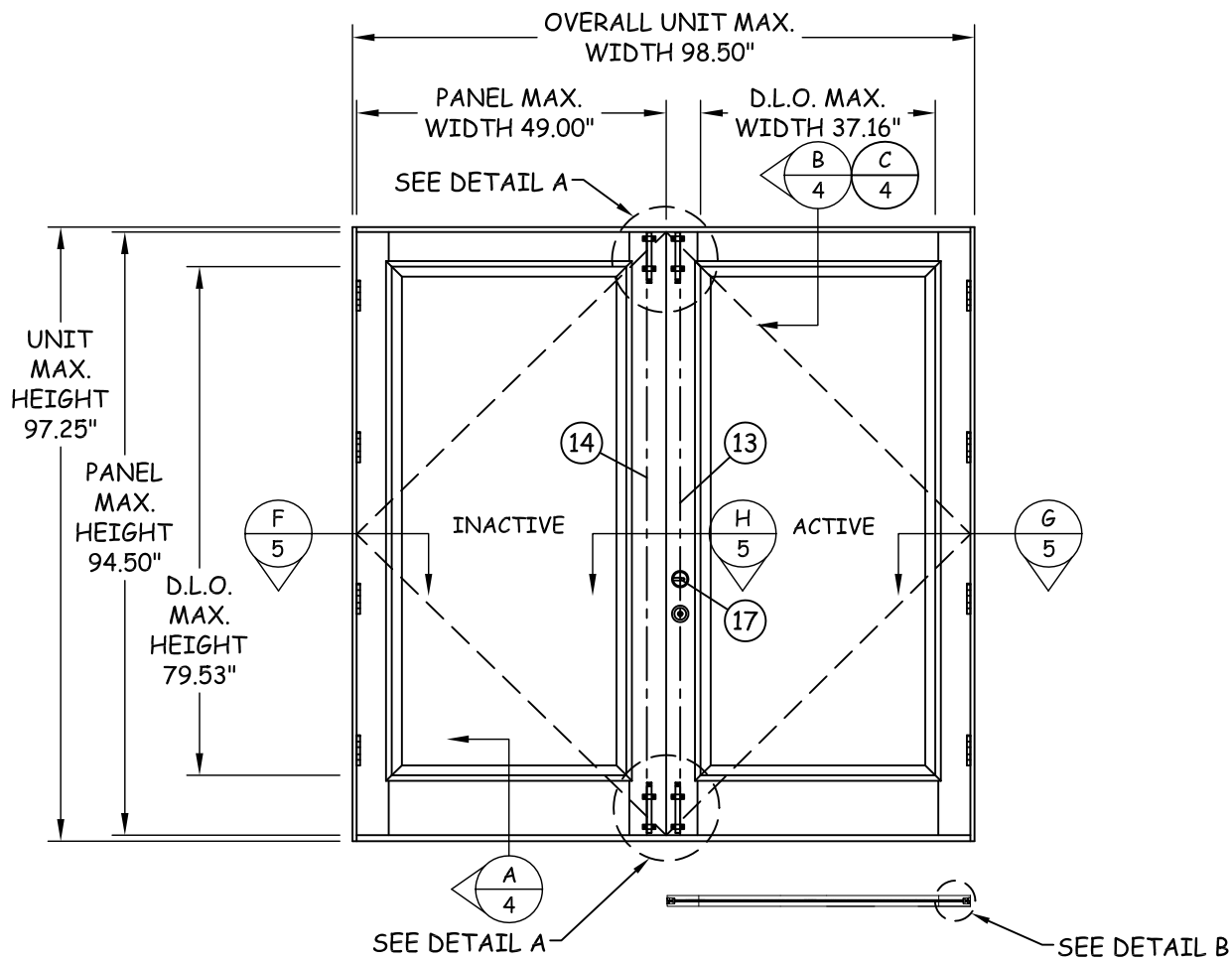

**ELEVATION**

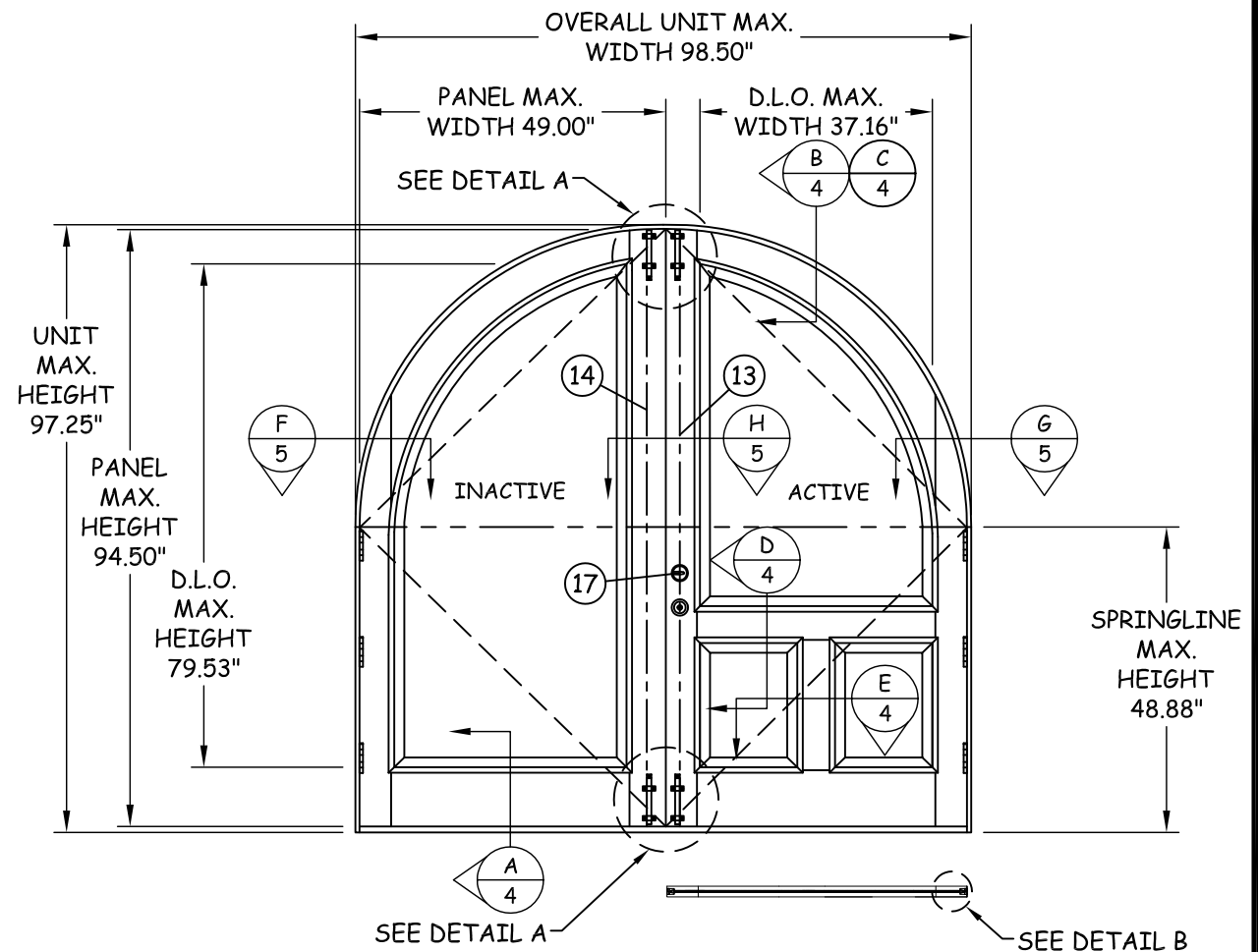

**ELEVATION**

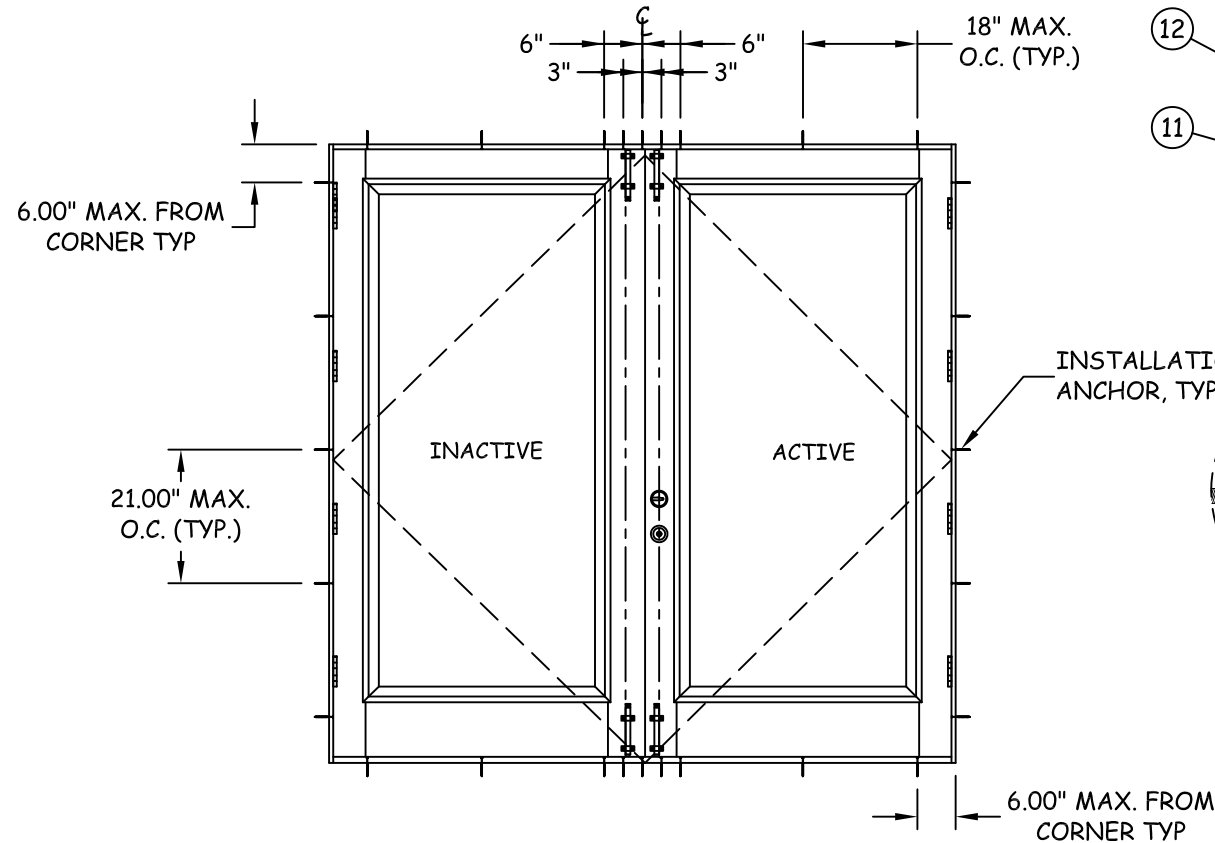

**ANCHOR LAYOUT**

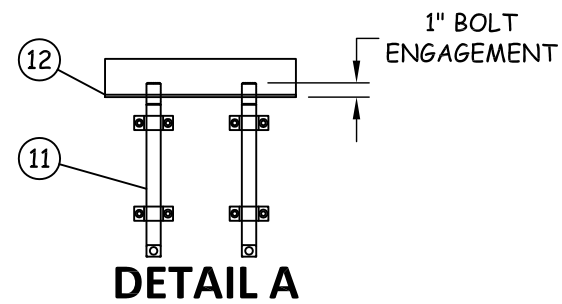

**DETAIL A**

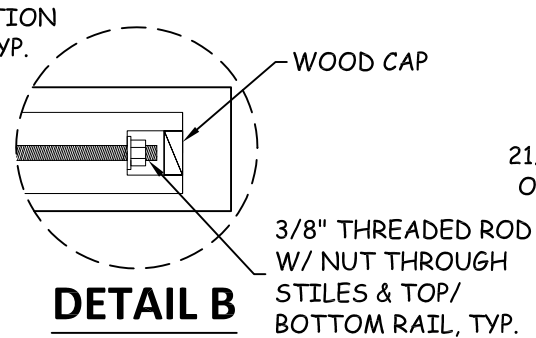

**DETAIL B**

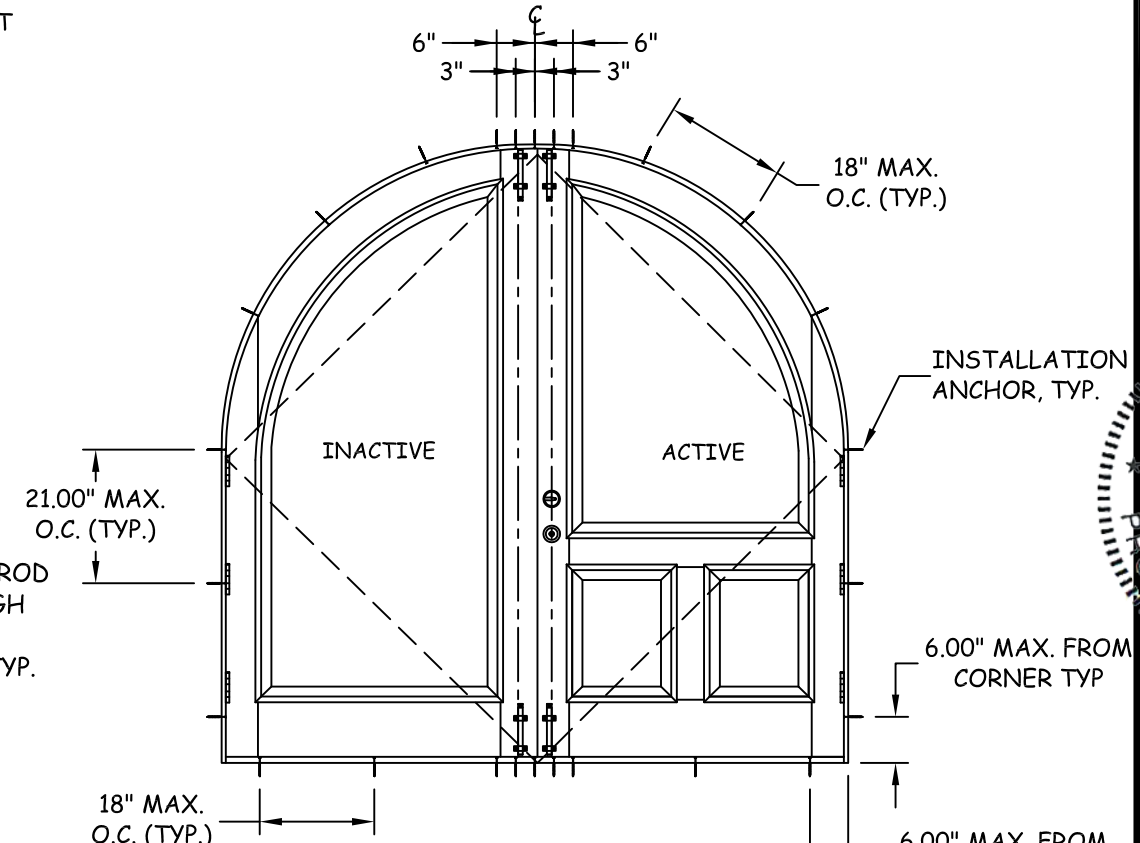

**ANCHOR LAYOUT**

**REVISIONS**

NO.	DESCRIPTION	BY	DATE

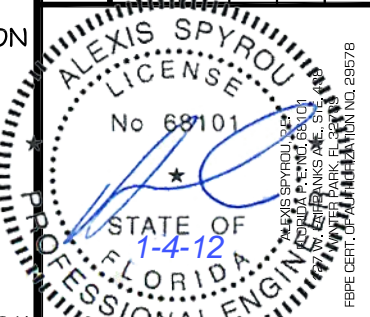

DATE: 12.08.11  
DWN BY: JLA  
CHK BY: HFN  
SCALE: NTS

DWG #: **ETO005**  
SHEET: **2 OF 7**

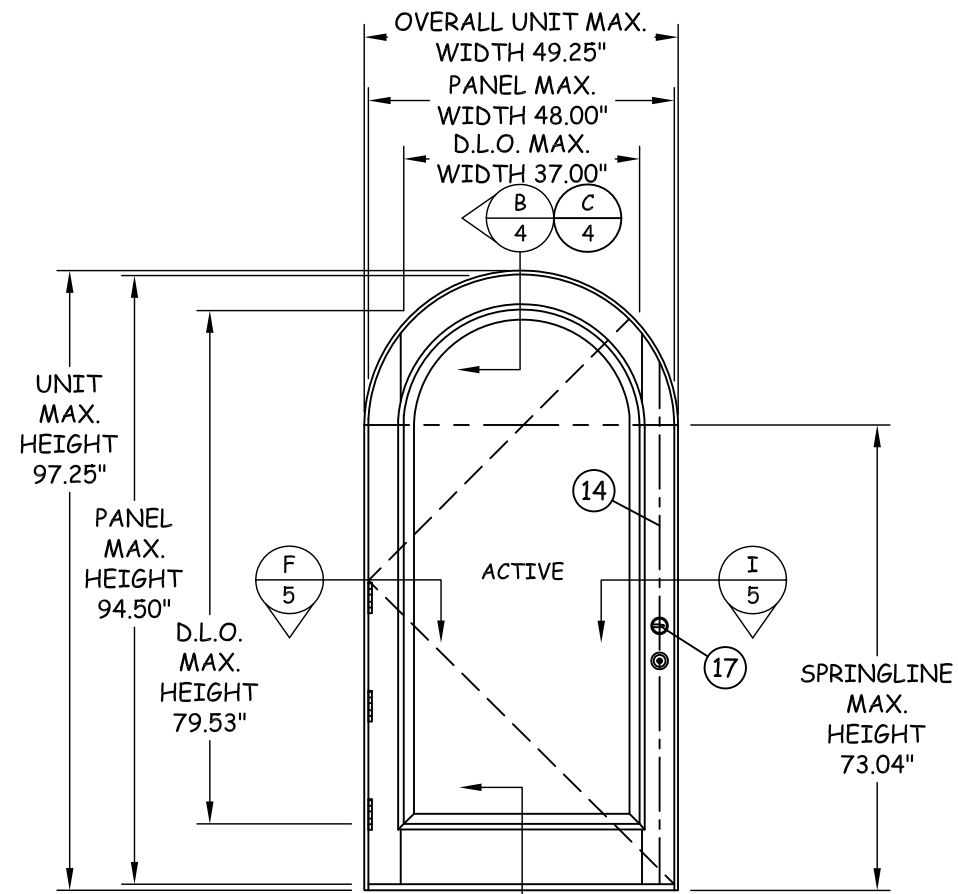

**ELEVATION** SEE DETAIL B

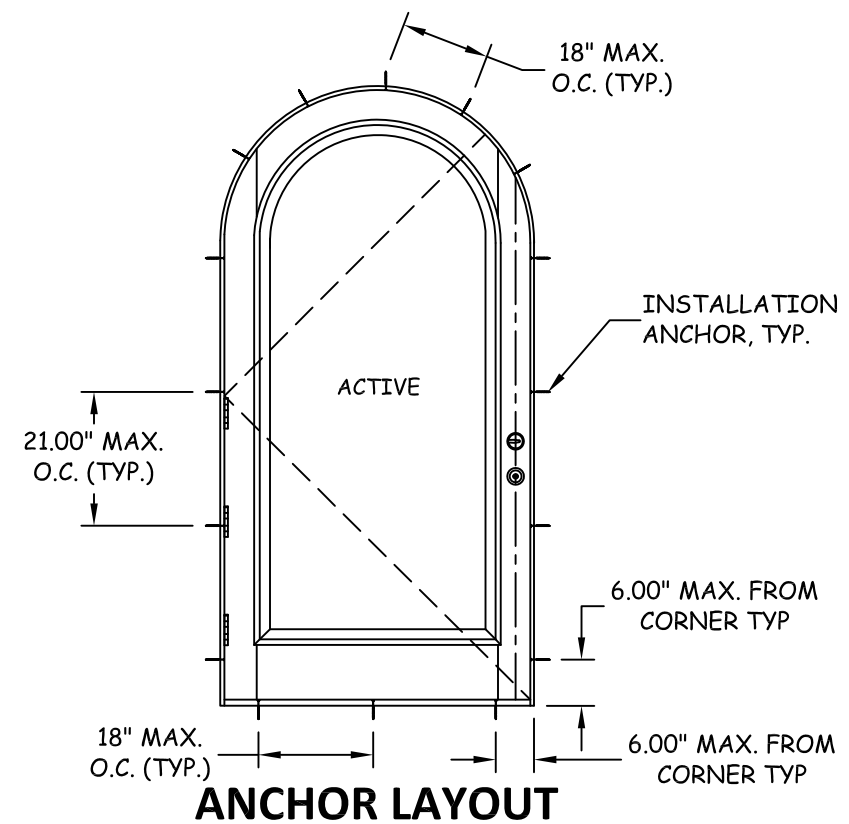

**ANCHOR LAYOUT**

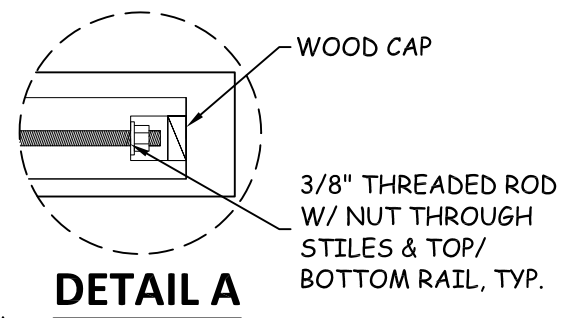

**DETAIL A**

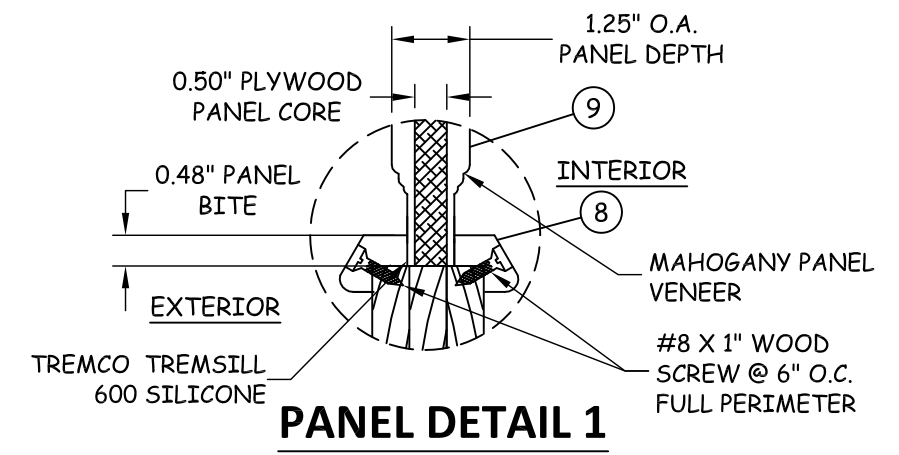

**PANEL DETAIL 1**

TITLE: WOOD OPAQUE I/S  
IMPACT RATED DOORS  
ELEVATION, ANCHOR LAYOUT,  
& PANEL DETAIL

PREPARED BY:  
BUILDING DROPS  
127 W. FAIRBANKS AVE., STE. 438  
WINTER PARK, FL 32789  
PH: (407) 644-6957 FX: (407) 644-2366

NO.	DESCRIPTION	BY	DATE

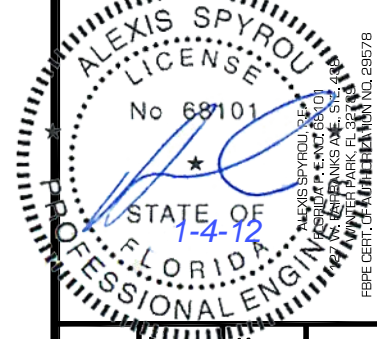

DATE: 12.08.11  
DWN BY: JLA  
CHK BY: HFN  
SCALE: NTS

DWG #: **ETO005**

SHEET: 3 OF 7



TITLE: WOOD OPAQUE I/S  
IMPACT RATED DOORS  
VERTICAL  
& HORIZONTAL SECTIONS

PREPARED BY:  
BUILDING DROPS  
127 W. FAIRBANKS AVE., STE. 438  
WINTER PARK, FL 32789  
PH: (407) 644-6957 FX: (407) 644-2366

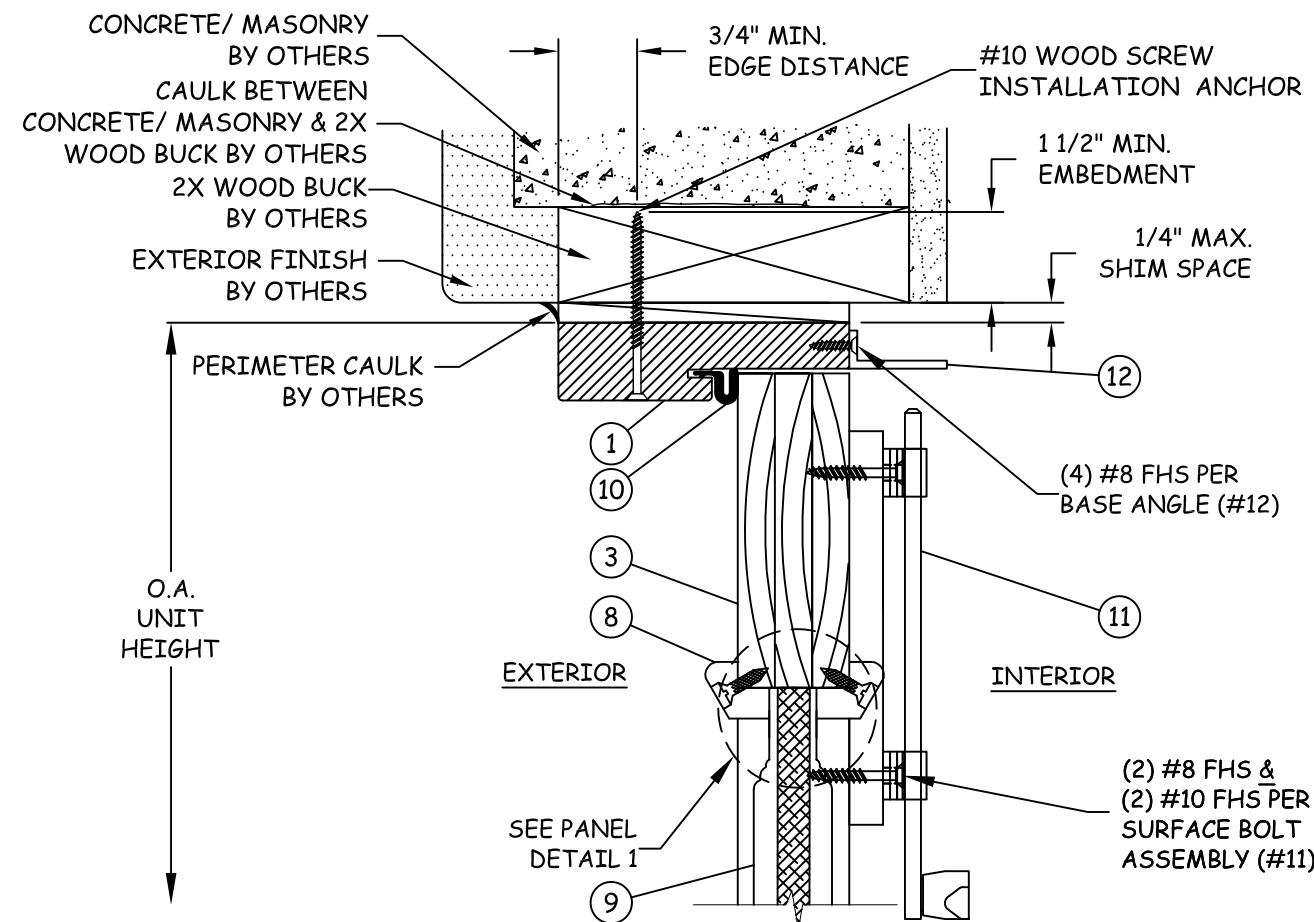

**B**  
**4** VERTICAL SECTION  
HEAD - 2X WOOD BUCK

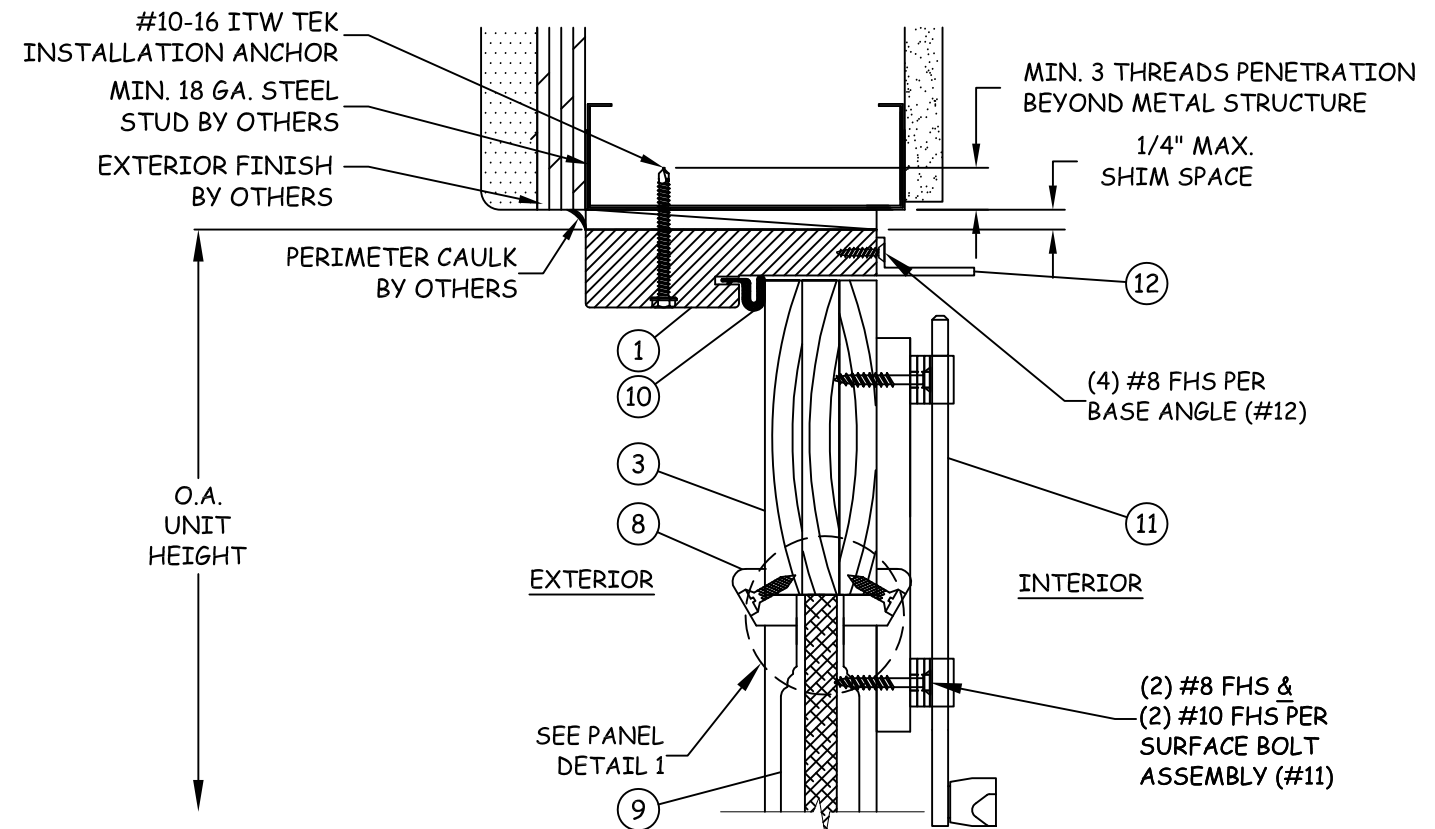

**C**  
**4** VERTICAL SECTION  
HEAD - STEEL STUD

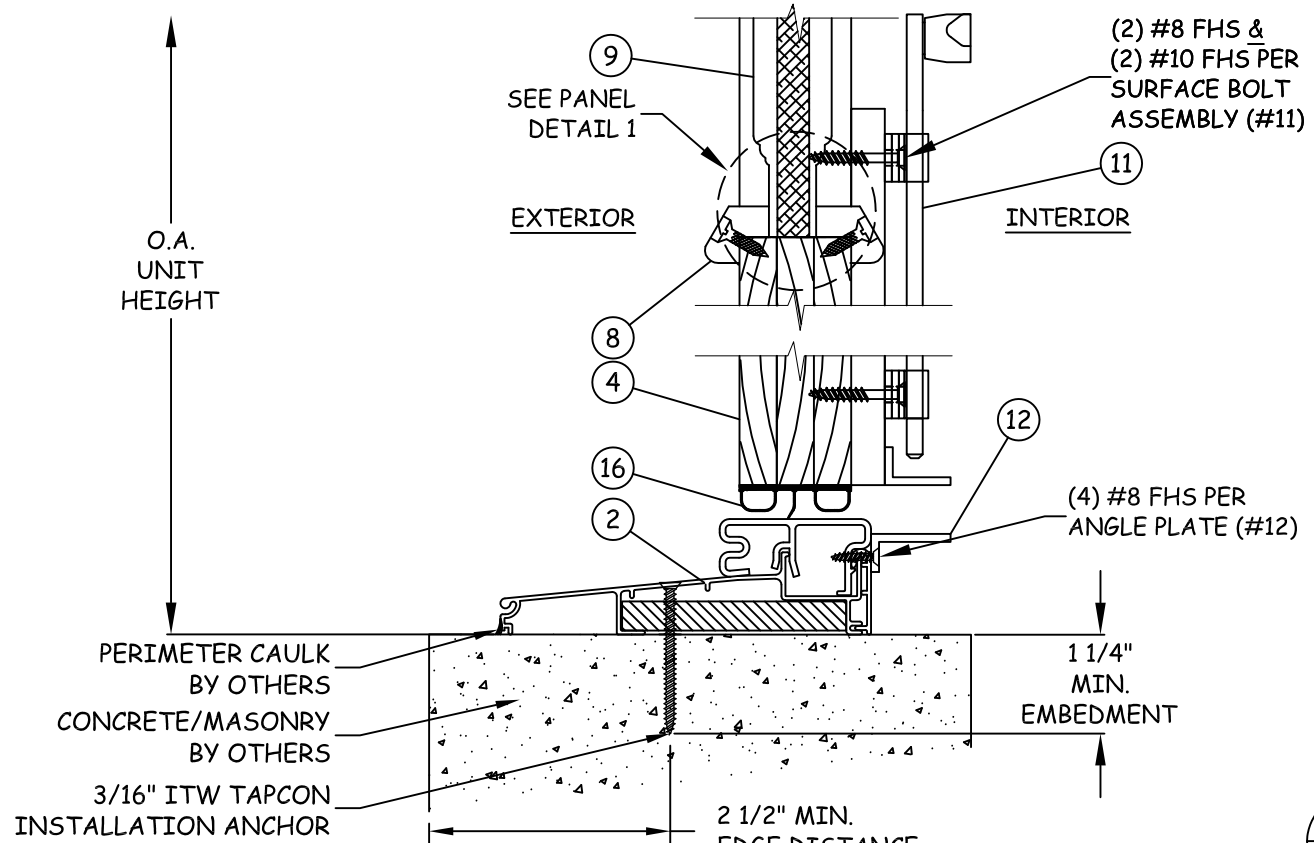

**A**  
**4** VERTICAL SECTION  
SILL - CONCRETE/MASONRY

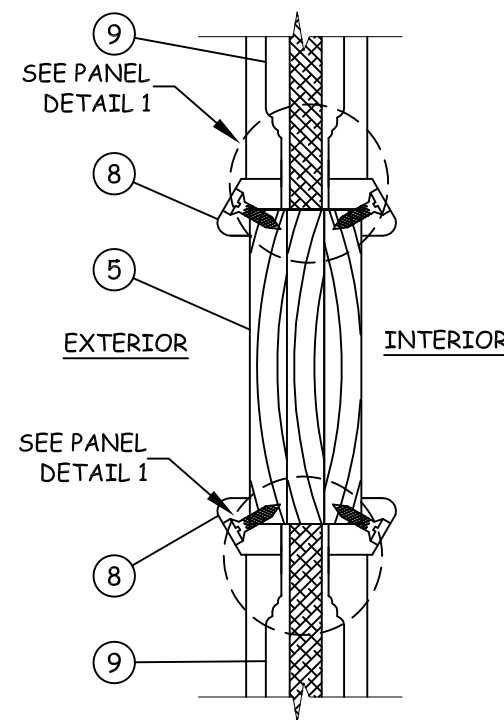

**D**  
**4** VERTICAL SECTION  
MIDRAIL - OPAQUE

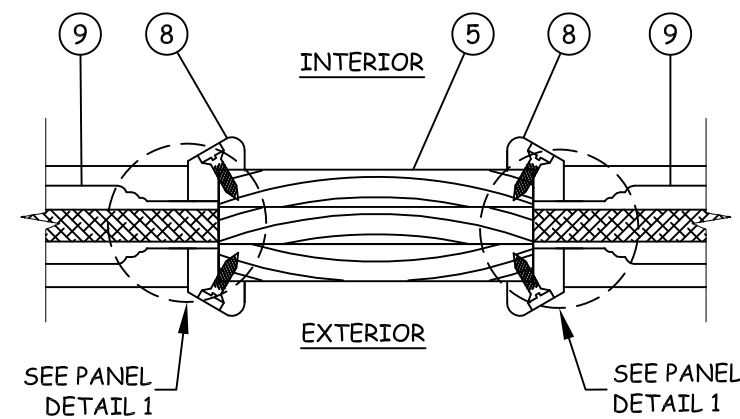

**E**  
**4** HORIZONTAL SECTION  
MIDSTILE - OPAQUE

## REVISIONS

NO.	DESCRIPTION	BY	DATE

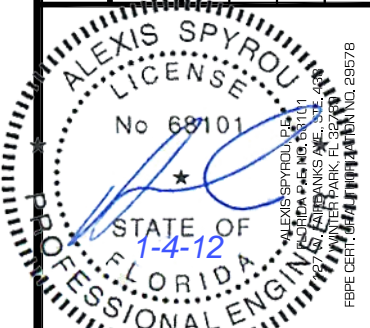

DATE: 12.08.11  
DWN BY: JLA  
CHK BY: HFN  
SCALE: NTS

DWG #: **ETO005**  
SHEET: **4 OF 7**

TITLE: WOOD OPAQUE I/S  
IMPACT RATED DOORS  
HORIZONTAL SECTIONS

PREPARED BY:  
BUILDING DROPS  
127 W. FAIRBANKS AVE., STE. 438  
WINTER PARK, FL 32789  
PH: (407) 644-6987 FX: (407) 644-2366

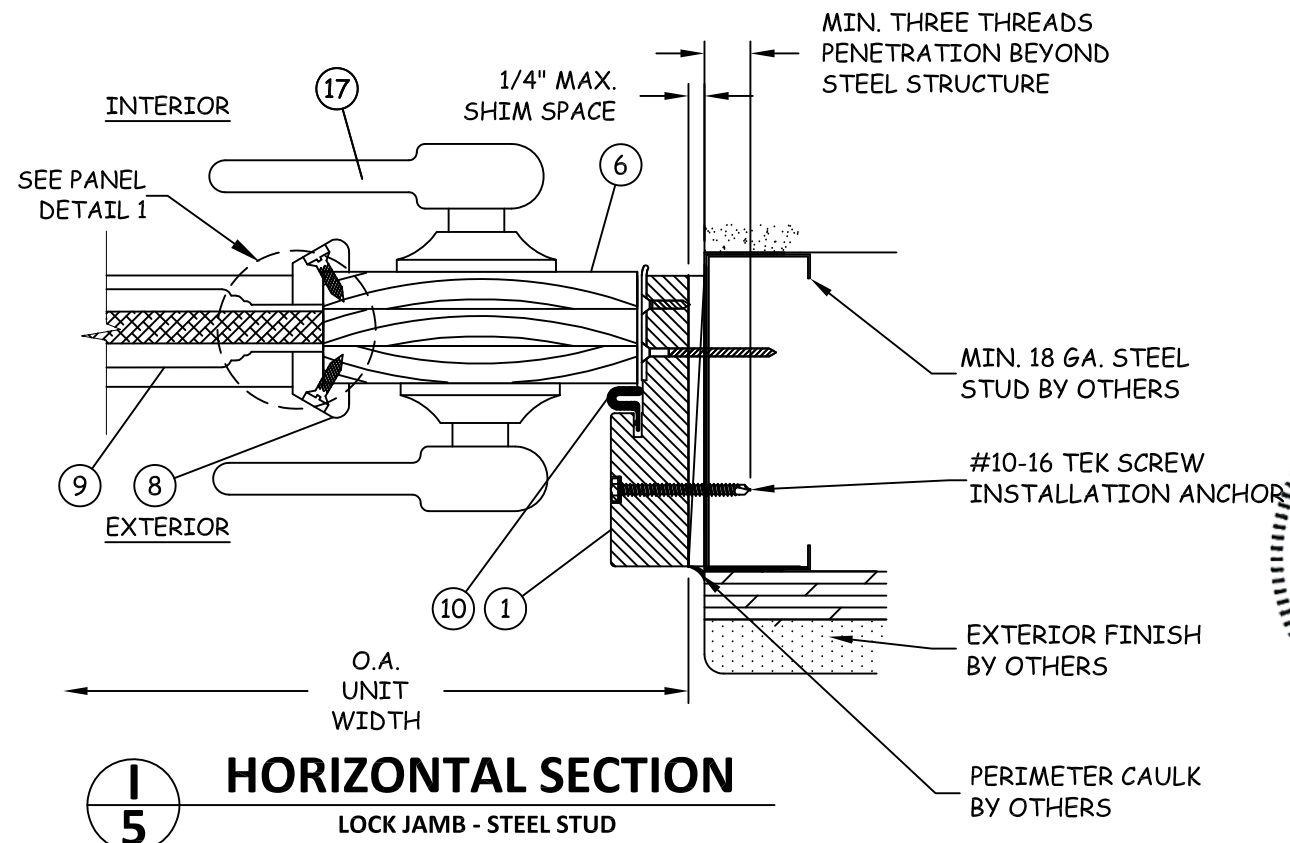
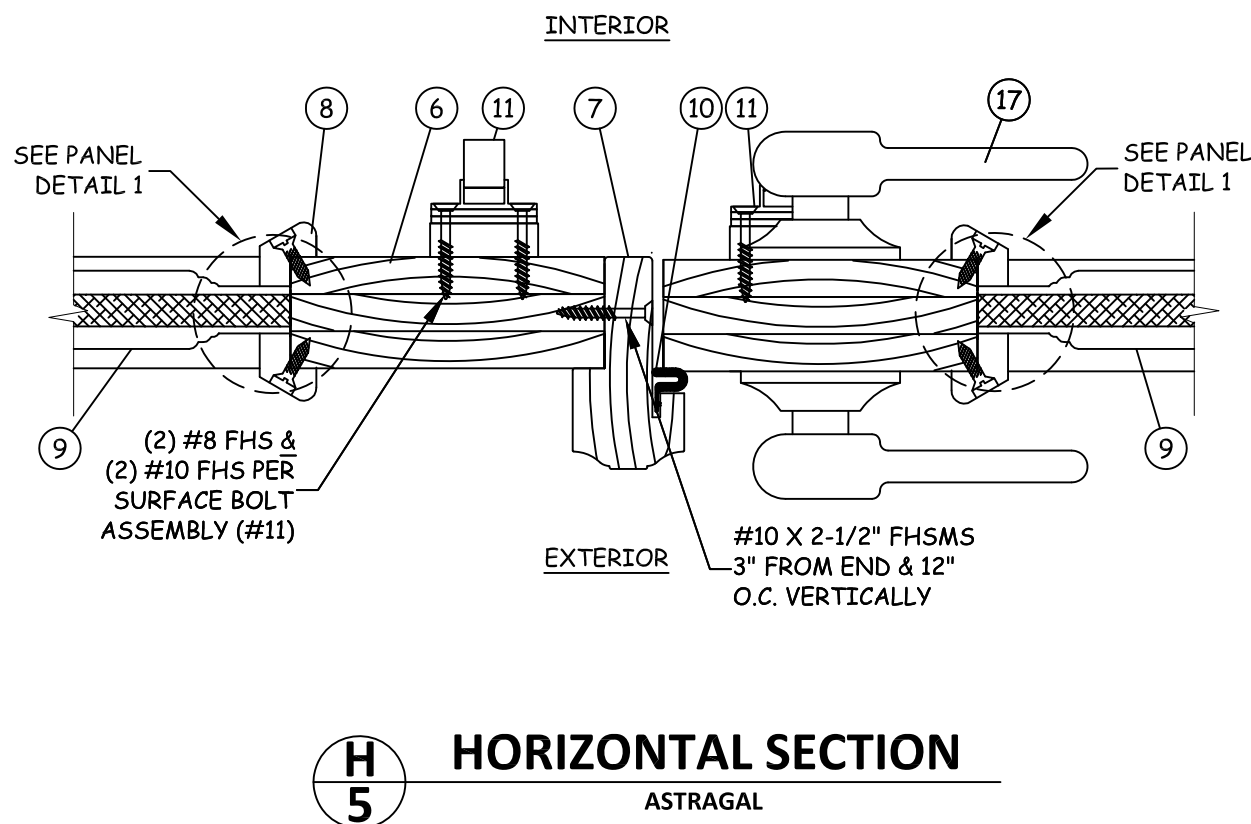
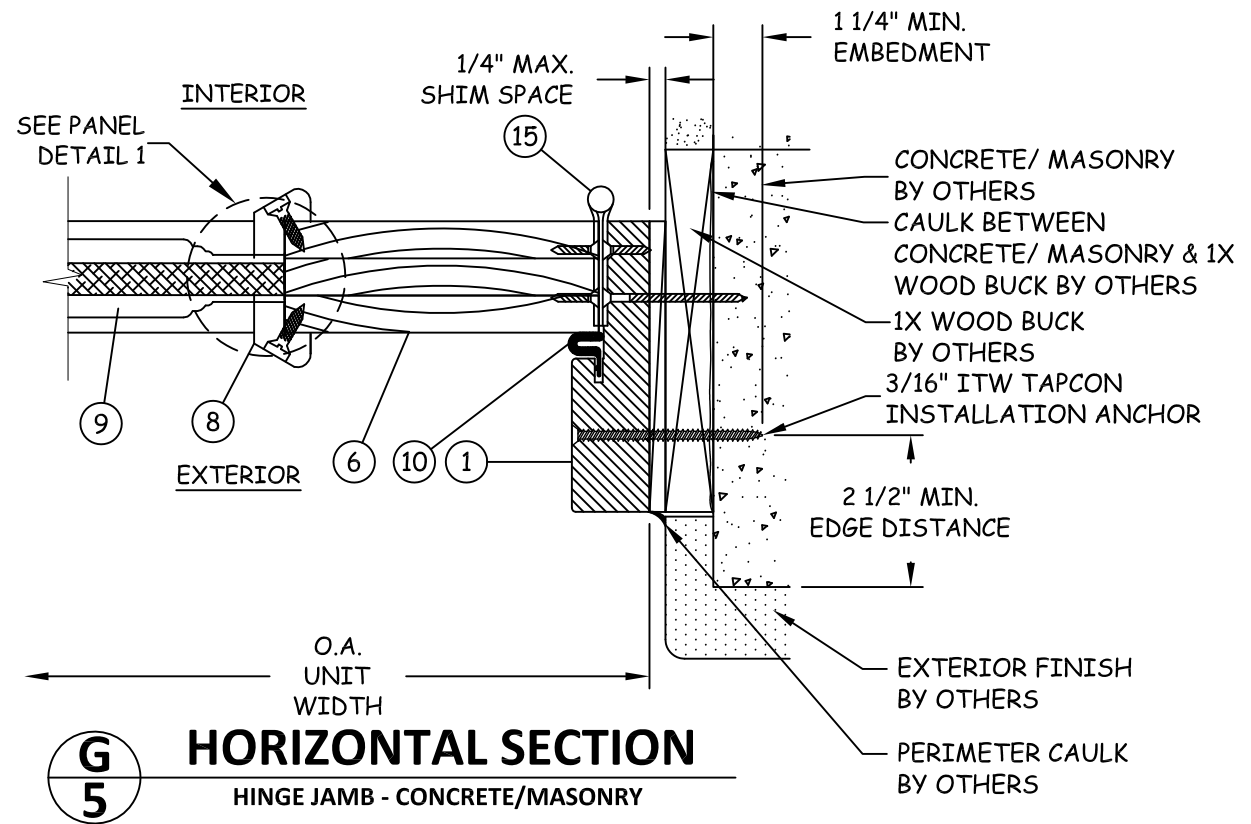
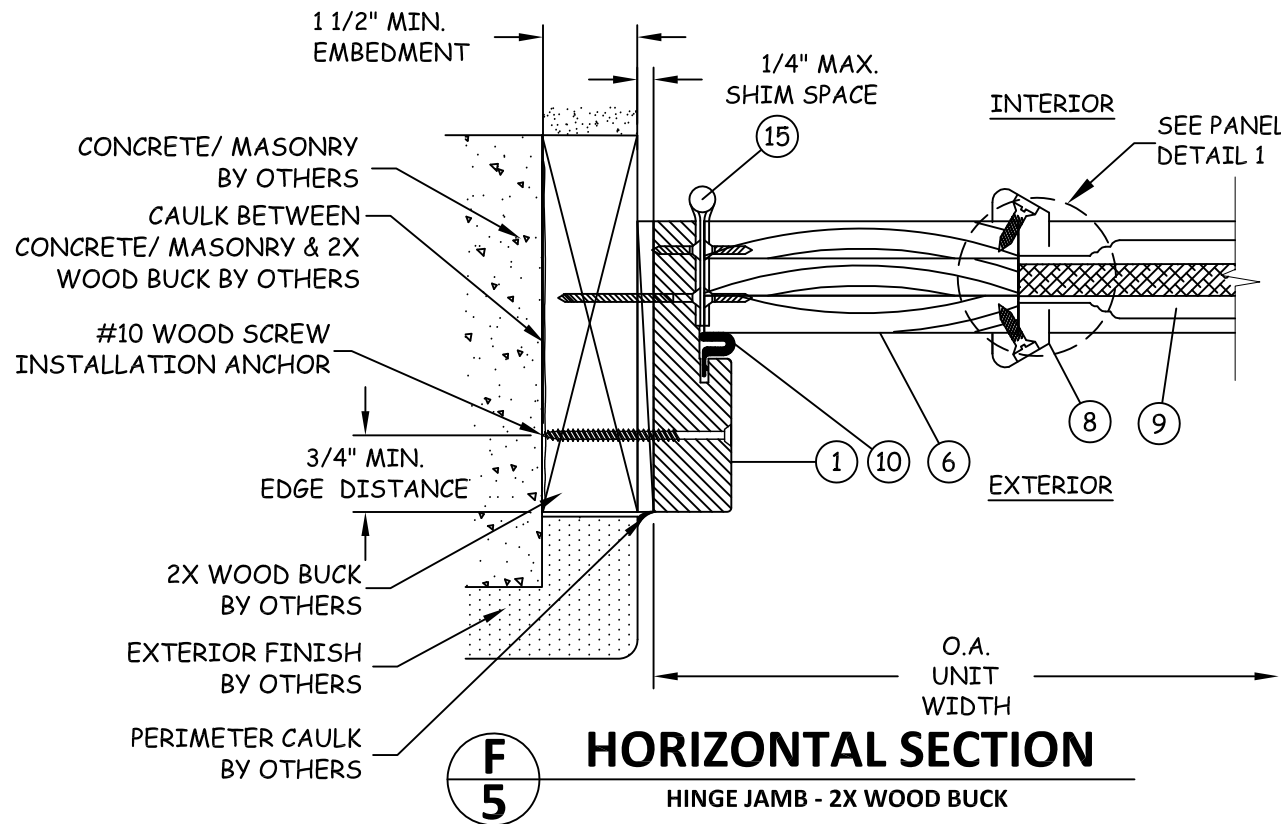

## REVISIONS

NO.	DESCRIPTION	BY	DATE

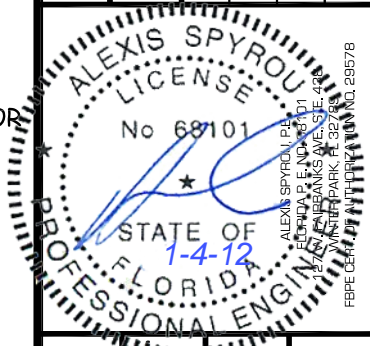

DATE: 12.08.11	DWN BY: JLA	CHK BY: HFN	SCALE: NTS
-------------------	----------------	----------------	---------------

DWG #:  
**ETO005**  
SHEET: **5 OF 7**

**BILL OF MATERIALS**

ITEM NO.	DESCRIPTION	MATERIAL	MANUFACTURER/NOTES
1	DOOR FRAME	MAHOGANY	ETO DOORS
2	OUTSWING THRESHOLD	ALUMINUM	ENDURA
3	TOP RAIL	MAHOGANY	ETO DOORS
4	BOTTOM RAIL	MAHOGANY	ETO DOORS
5	MIDRAIL	MAHOGANY	ETO DOORS
6	STILE	MAHOGANY	ETO DOORS
7	ASTRAGAL	MAHOGANY	ETO DOORS
8	GLASS STOP	MAHOGANY	ETO DOORS
9	RAISED PANEL	MAHOGANY W/ PLYWOOD CORE	ETO DOORS
10	WEATHERSTRIP	Q-LON	SCHLEGEL
11	SURFACE BOLTS	STAINLESS STEEL	ROCKWOOD
12	STRIKE PLATE	STAINLESS STEEL	--
13	3 POINT LOCK SYSTEM	STEEL	W&F 3000-1-4070
14	2 POINT LOCK SYSTEM	STEEL	W&F 3027-12-6033
15	HINGE	STEEL	HAGAR
16	DOOR SWEEP	VINYL	--
17	DEADBOLT LOCK	STEEL	HUTTIG/C&C

**NOTES:**

1. MAHOGANY MIN. S.G.=0.44
2. IN ACCORDANCE WITH THE 2007 & 2010 FBC, SECTION 2411.3.3.3 ALL WOOD COMPONENTS SHALL HAVE BEEN PRESERVATIVE TREATED OR SHALL BE OF A DURABLE SPECIES AS DEFINED IN SECTION 2326.2.

**1 DOOR FRAME MAHOGANY**

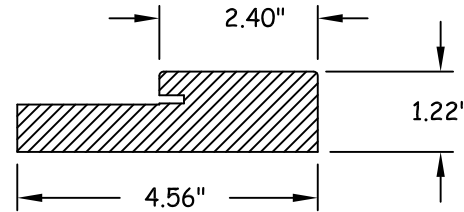

**2 OUTSWING THRESHOLD ALUMINUM 6063-T5 W/ OAK FILLER**

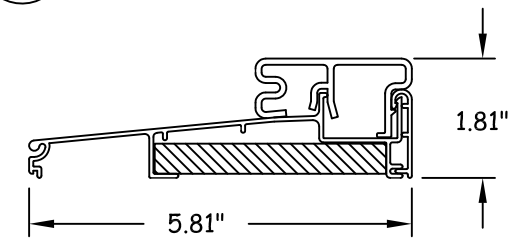

**3 TOP RAIL MAHOGANY**

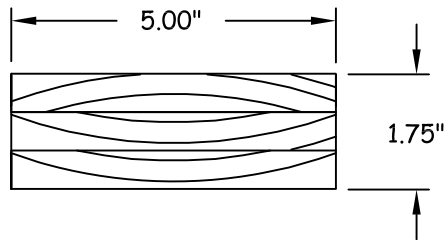

**4 BOTTOM RAIL MAHOGANY**

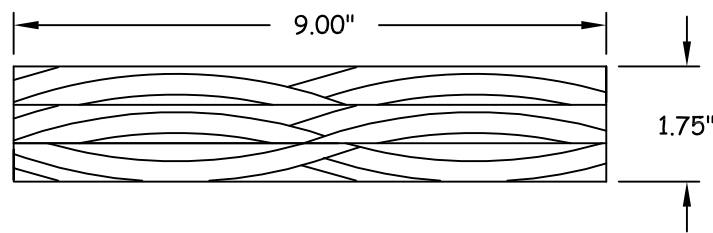

**5 MIDRAIL MAHOGANY**

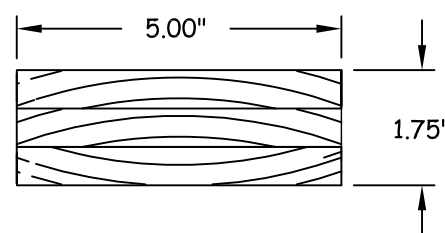

**6 STILE MAHOGANY**

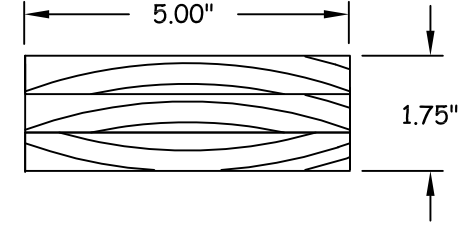

**7 ASTRAGAL MAHOGANY**

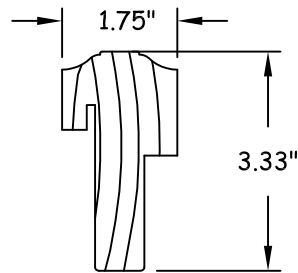

**8 PANEL STOP MAHOGANY**

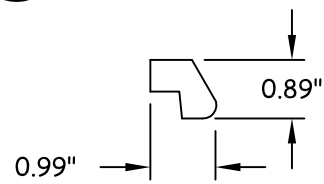

**9 RAISED PANEL MAHOGANY W/ PLYWOOD CORE**

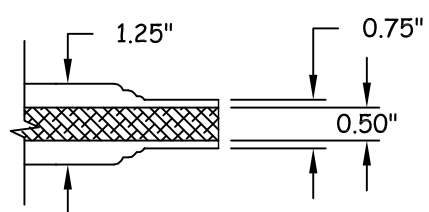

**13 3 POINT LOCK SYSTEM STEEL**

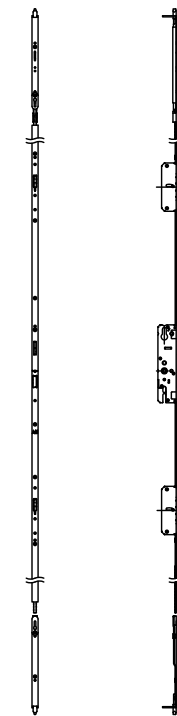

**14 2 POINT LOCK SYSTEM STEEL**

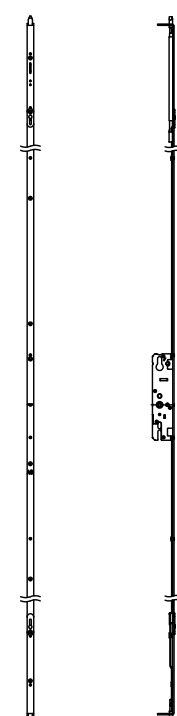

**10 WEATHERSTRIP Q-LON**

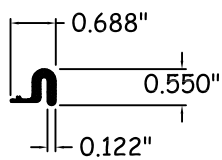

**11 SURFACE BOLT STAINLESS STEEL**

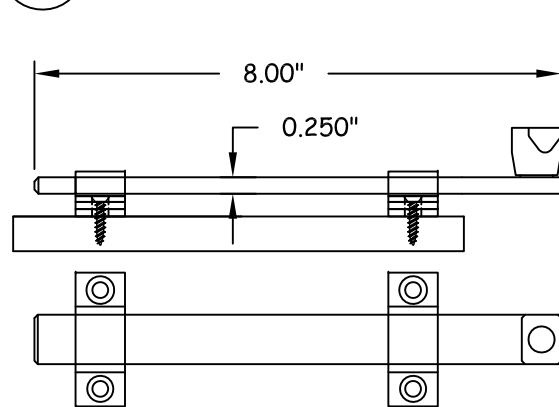

**12 BASE ANGLE 1/8" STAINLESS STEEL**

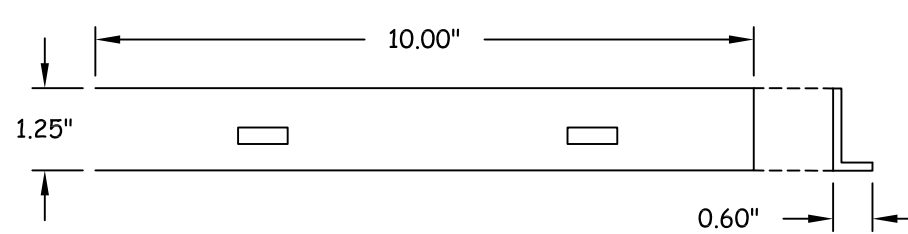

ETO DOORS  
1340 E. 6TH STREET  
LOS ANGELES, CA 90021  
PH: (213) 622-2003  
WWW.ETODOORS.COM

TITLE: WOOD OPAQUE I/S  
IMPACT RATED DOORS  
COMPONENTS  
& BILL OF MATERIALS

PREPARED BY:  
BUILDING DROPS  
127 W. FAIRBANKS AVE., STE. 438  
WINTER PARK, FL 32789  
PH: (407) 644-6957 FX: (407) 644-2366

REVISIONS	NO.	DESCRIPTION	BY	DATE

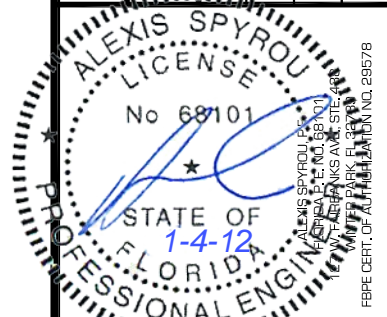

DATE: 12.08.11	DWN BY: JLA	CHK BY: HFN	SCALE: NTS
DWG #: <b>ETO005</b>			
SHEET: <b>6 OF 7</b>			





ETO DOORS  
 1340 E. 6TH STREET  
 LOS ANGELES, CA 90021  
 PH: (213) 622-2003  
 WWW.ETODOORS.COM

48.00" MAX.  
 WIDTH

95.50" MAX.  
 HEIGHT

\* ALL ELEVATIONS SHOWN ALSO QUALIFY 84" AND 80" HEIGHTS AND ANY OTHER CUSTOM SIZES SMALLER THAN TESTED.

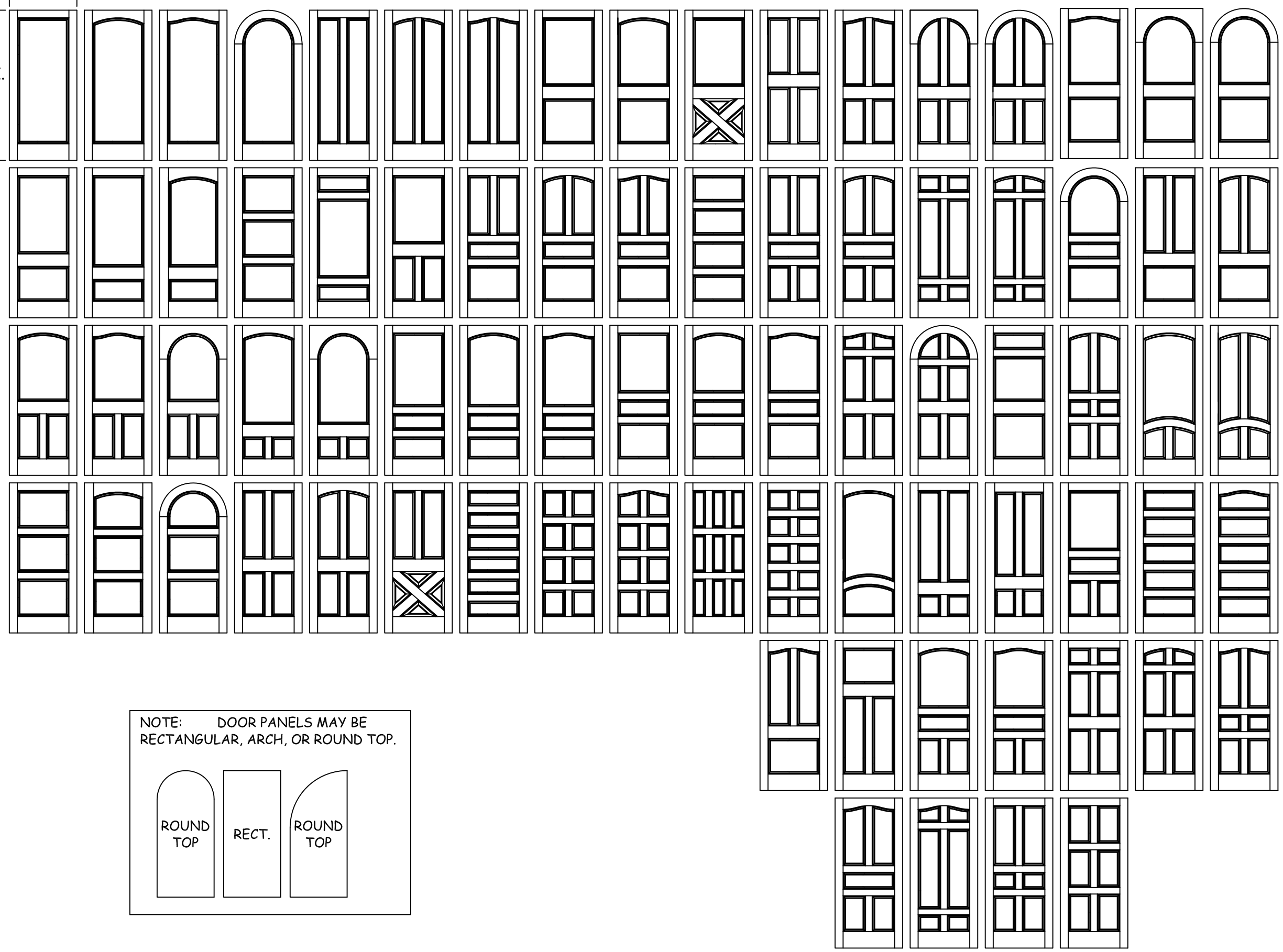

NOTE: DOOR PANELS MAY BE  
 RECTANGULAR, ARCH, OR ROUND TOP.

ROUND TOP    RECT.    ROUND TOP

TITLE: WOOD OPAQUE I/S  
 IMPACT RATED DOORS  
 QUALIFIED  
 CONFIGURATIONS

PREPARED BY:  
 BUILDING DROPS  
 127 W. FAIRBANKS AVE., STE. 438  
 WINTER PARK, FL 32789  
 PH: (407) 644-6957    FX: (407) 644-2366

REVISIONS		NO.	DESCRIPTION	BY	DATE

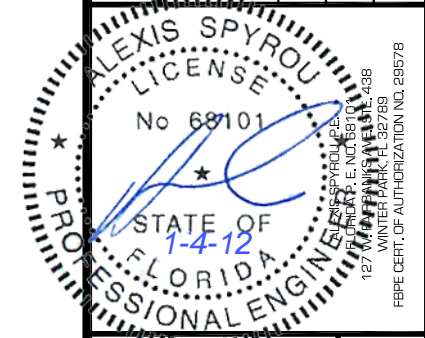

DATE: 12.08.11  
 DWN BY: JLA  
 CHK BY: HFN  
 SCALE: NTS

DWG #: ETO005

SHEET: 7 OF 7